

DX100 mk2

Single Zone Lighting Control Unit

INSTALLATION AND OPERATING INSTRUCTIONS

FORWARD

The DX100 forms the heart of a security system which can switch on mains lighting and operate audible warning accessories. Additional accessories can be added to enhance the system such as a "PC35" for CCTV interface. Up to 8 GX200 detectors can be connected to the DX100 all of which will operate the same lights and sounders. It is usual to have sounders both day and night whilst only the lights operate at night. This is achieved by using a "PC30" module which controls the sounders. The GX200 detectors have light sensors inside them which are used to deactivate the lighting during day light hours. The DX100 plastic case is weather proof to IP65 and is suitable for outside use.

FIXING, INTERIOR OR EXTERIOR

The DX100 can be situated where it is convenient to connect to the mains supply, i.e. garage or attic etc. There are four small countersunk holes in the case to take screws for fixing. Cable entry to the case should be made by cutting 20mm holes and fitting water tight glands in order to maintain the IP66 rating and provide cable anchorage in accordance with I.E.E. regulations. Two rubber grommets are supplied for use where the IP rating is not important but cable anchorage will still be required. If in doubt consult a qualified electrician.

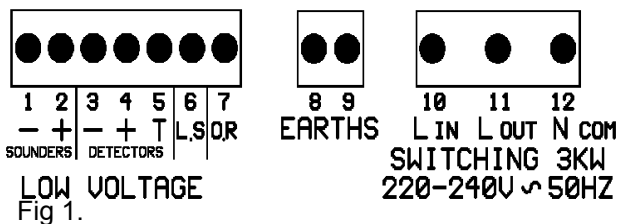

SPECIFICATION

- Mains input voltage 220-240 Volts ~ 50HZ
- Power supply 500 m/a
- Detector output voltage 12 volts DC 300ma
- Sounder output 12Volts 100ma
- Relay switching capacity 3000 Watts
- Timer adjustable from 3 seconds to 10 minutes
- Light sensor adjustable Day through to Night

MAINS CONNECTION TO THE DX100

Supply a twin & earth cable (1.5 -2.5mm) from a 20 amp switched spur and connect the LINE & NEUTRAL to terminals 10 (L in) and 12 (N com). Two earth terminals are provided for your convenience for joining earth's together. Terminals 8 & 9.

FLOODLIGHT CONNECTIONS TO THE DX100

Connect floodlights to terminals 11 (L out) and 12 (N com).

LOW VOLTAGE OVER-RIDE

To manually over-ride the flood lights so they remain on for long periods simply connect your switch across terminals 3 and 7. It is not necessary to use mains cable with the DX100. Instead you can use low voltage cable and a low voltage switch. The cable and switch will only operate at 12 volts DC. The idea is to make the power relay on the DX100 do the mains switching and control it with the low voltage circuitry.

MAINS VOLTAGE OVER-RIDE

If you want to over-ride the floodlights you must use the appropriate voltage rating mains wiring and mains switch. Connect the switch across terminals 10 and 11.

THE TIMER

The timer is a top-up type and with the (green) adjuster marked (timer) turned fully anti-clockwise has a minimum time of approximately 3 seconds. Turning the adjuster fully clockwise will increase the time to a maximum of 10 minutes approximately. If further movement is detected during the timing period, the timer will re-start.

LIGHT SENSOR

The light sensor input inhibits the DX100 during day light hours and is adjustable. (Red adjuster). Fully anti-clockwise will allow the DX100 to operate during day light hours. When turned fully clockwise the DX100 will only work at night and by retarding the control by degrees allows the system to operate in lighter conditions. Only one light sensor is wired back to the DX100 regardless of how many detectors you have. See wiring examples.

DETECTOR WIRING

The detectors may be wired in a chain or alternatively wired back separately to the control unit using 4 core alarm cable (7/2/4) or telephone cable. See "WIRING EXAMPLES". Choose a suitable circuit from the wiring examples or modify one to suit your own particular requirements. All GX200 detectors have built in light sensors. The light sensor connects to negative in the GX200 and terminal 6 in the DX100. The six terminals in the GX200 are marked as follows.

TB & TY	Normally closed contacts going momentarily open on detection.
+ & -	12 Volt DC input.
L & S	Light sensor output.

WIRING PROCEDURE EXPLAINED.

The detectors can be thought of as "normally closed" switches which open circuit momentarily when movement is detected. The detectors switch contacts are marked TB & TY. The detectors must be wired in "SERIES" as shown in (fig.2). One end of the chain is connected to Negative (- terminal 3) and the other end to the (T terminal 5) on the DX100.

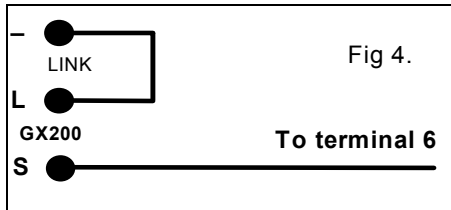
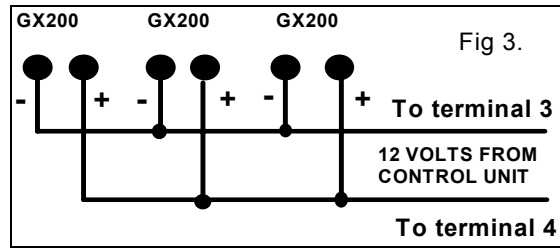
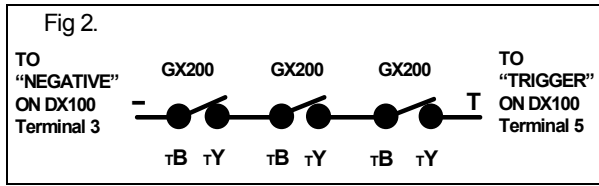

Each detector requires 12 volts DC in order to operate and this is connected to the + and - terminals. The 12 volts must be wired in "PARALLEL" as shown in (fig.3).

Link a light sensor to negative in one GX200 and return one wire to terminal no 6 (L/S) on the DX100 as shown in (fig.4.)

COMMISSIONING.

Switch on the DX100 and observe the red power light. Allow about two minutes for the detectors to settle before beginning the tests. Turn both the red and green adjusters fully anti-clockwise. Each time movement is detected by the GX200's the red trigger indicator will light. In addition the floodlights will come on for about 3 seconds and if any sounders are fitted they will also operate. Now observe the red indicators above the connector terminals in the GX200 detectors which will light each time movement is detected. Walk about within the detection area and make angle adjustments to the detector until satisfied with the coverage. The red indicator may be hard to see during day light but you will be able to see the floodlights coming on and off. When satisfied with the set up you can then turn the red light sensor adjuster clockwise to face about 2 'o' clock which is average and this will inhibit operation during day light hours. Now turn the green timer adjuster clockwise by degrees to the desired time setting. E.G.: Facing 12 'o' clock = 5 minutes. These settings are average for most applications.

TROUBLE SHOOTING

- PROBLEM** lights operate day and night regardless of (red) light sensor adjuster setting.
SOLUTION Make sure that one and only one light sensor has been used regardless of how many GX200's are used. The light sensor return wire may not be connected. Check for continuity.
- PROBLEM** Lights stay on all the time.
SOLUTION The most common cause is when terminal 5 (trigger) has been left open circuit. Make sure the detectors have been wired correctly using the circuit diagrams. To prove that the DX100 is working correctly simply turn the time control fully anti-clockwise and short out terminals 3 and 5 with a link of wire. The lights should go out after 4 seconds. If this happens, remove the link and check the wiring. Make sure that the detectors are not continuously detecting movement such as passing traffic.
- PROBLEM** Occasional false activations.
SOLUTION Cloud movement, reflections, small animals and close proximity foliage can all cause false activation's. Make sure that all climbing plants are cleared away from the detectors view. Switch the detectors to double count. Tape over the creep zones on the detector lens. Re-locate detectors to view the area from a different position. Use the PC80 pulse count accessory or PC85 dual PIR processor accessory which can be fitted inside the DX100 enclosure.

ACCESSORIES

PC30 24 hour bell timer.	PC80 pulse counter module
PC35 24 hour timer with voltage free changeover contacts	PC85 dual PIR processor module
EX3 12volt bleeper	Speed Dome 4x4 module

TECHNICAL HELPLINE 020 8361 5255

LUMINITE Electronics LTD
 2a Bellevue Road, Friern Barnet
 LONDON N11 3ER

Tel: 020 8368 7887 Fax: 020 8368 3952

TYPICAL WIRING EXAMPLES FOR GX200 DETECTORS TO DX100 Mk 2 SINGLE ZONE LIGHTING CONTROL UNITS

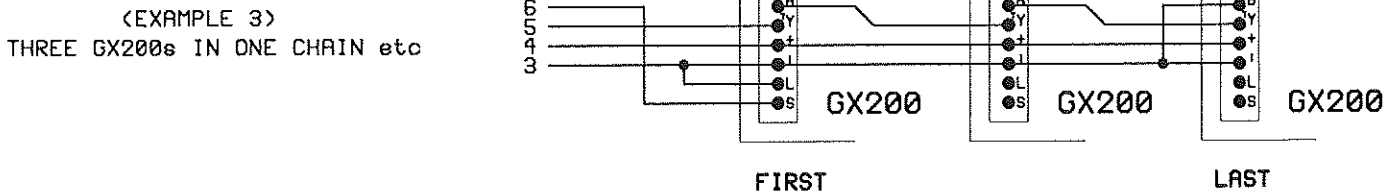
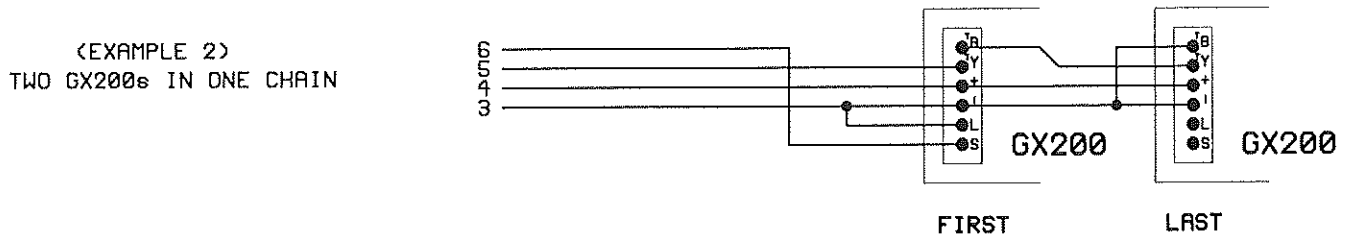
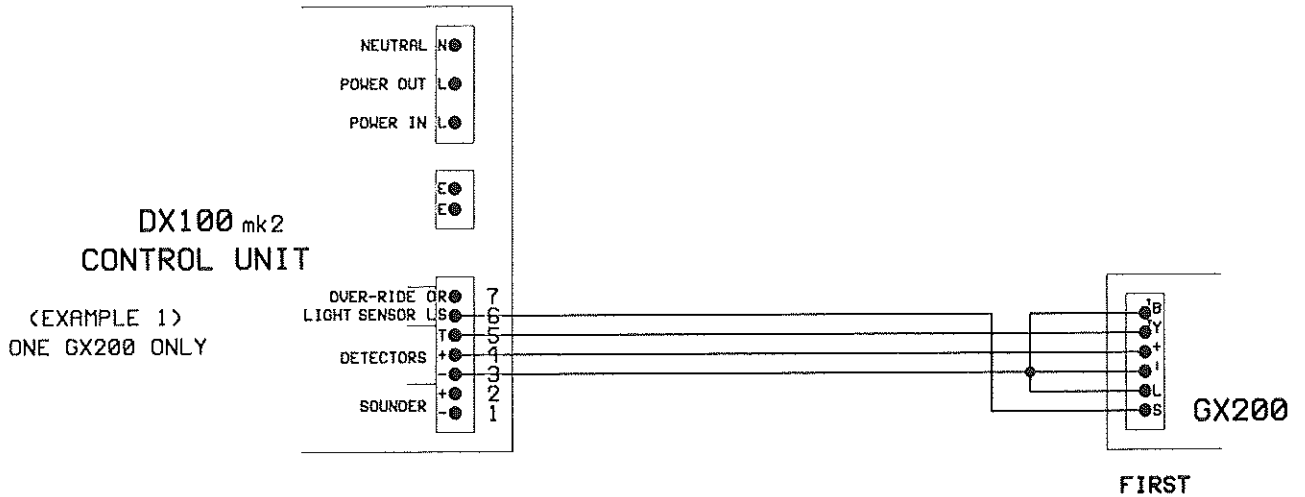

UP TO EIGHT DETECTORS MAY BE WIRED IN THIS WAY

(EXAMPLE 4)
 SIX GX200s IN TWO CHAINS

DX100_{mk2} CONTROL UNIT

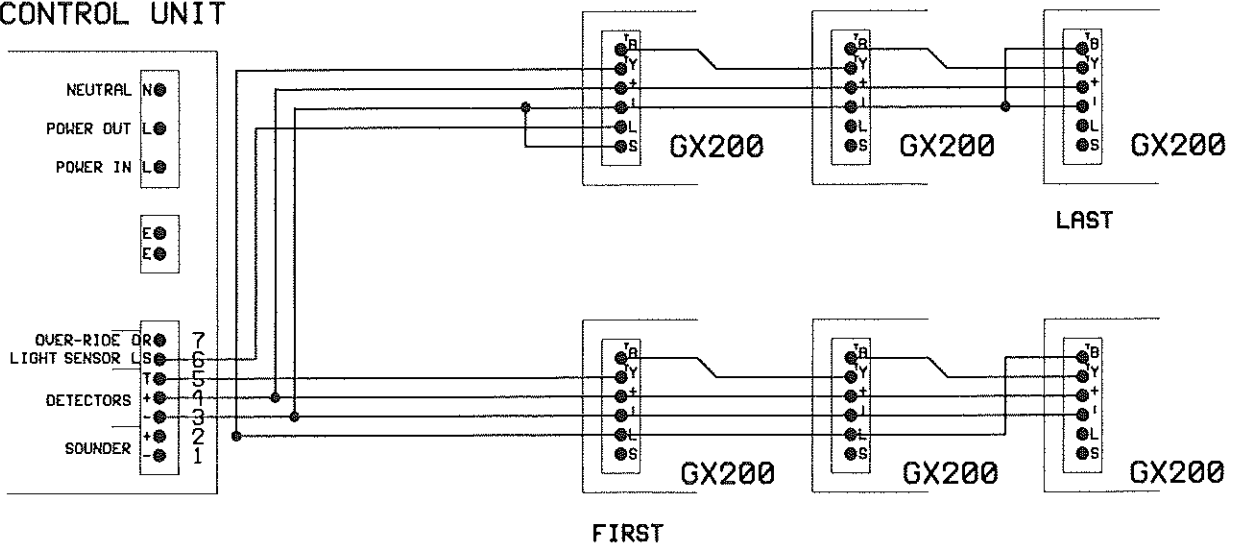

PLEASE NOTE :

FROM THE (FIRST) P.I.R. TO THE NEXT P.I.R.
 THE TERMINALS (L) ARE USED TO LINK FOR EASY WIRING.